

**INSTRUCTION MANUAL**  
**FOR**  
**MANUALLY OPERATED**  
**TCG-2500 GANGWAY**



---

**TABLE OF CONTENTS**

Section 1).....READ THIS FIRST

Section 2).....INTRODUCTION

Section 3).....IMPORTANT SAFETY INFORMATION

Section 4).....PRODUCT DESCRIPTION

Section 5).....ASSEMBLY

Section 6).....OPERATION

Section 7).....MAINTENANCE

Section 8).....EXTENDED INSPECTION ADDENDUM

Section 9).....MANUAL BRAKE ADJUSTMENT ADDENDUM

Section 10).....LIFT RESISTING DEVICE ADDENDUM

Section 11).....DRAWINGS AND SPECIFICATIONS

---

## 1) READ THIS FIRST

### a) GENERAL

- i) This Installation, Operation, and Maintenance manual is considered an integral part of the Carbis equipment to which it applies. It is the Owner's responsibility to ensure that personnel who operate and maintain the Carbis equipment receive comprehensive training in the operation and maintenance of the equipment, including adjustments where required. Operating and Maintenance personnel must also be familiar with the basic characteristics of the equipment so as to avert errors that might result in equipment damage or personnel injury. It is also the Owner's responsibility to ensure that maintenance activities are appropriately documented, including any abnormal operating condition and its associated root cause evaluation, followed by corrective actions implemented to eliminate recurrence.
- ii) Aging of equipment and associated service life-limiting variables, such as corrosion, fatigue, wear, etc., must be remedied during maintenance periods to preclude operational failure.
- iii) While this manual provides guidance to operating personnel in the matter of safe operation and recommended practices, it is not, and cannot be, a substitute for well-trained operations personnel. For a successful and trouble-free operation, great reliance must be placed upon the knowledge, background, and experience of the operating personnel, with this manual serving as a guide. The warranty on the equipment is automatically voided if the information contained in this manual is disregarded, whether inadvertently or willfully.

### b) VEHICLE POSITIONING

- i) Carbis gangways are designed in a variety of standard styles, sizes, and materials to accommodate customer-specific requirements in applications that include varying heights and types of vehicles. Subsequently, with each gangway, Carbis provides customer-approved Engineering Drawings and/or scope data that document key dimensional relationships between the vehicle and the gangway, including safety cages where applicable. Refer to the specific customer-approved Final Drawings for familiarization with the dimensional relationships between Carbis equipment and the vehicle to determine the necessary steps required to position the vehicle for proper operation.
- ii) RAIL CAR POSITIONING  
With the centerline of the rail car being a fixed, constant relationship with Carbis equipment, the only remaining position that requires operator input is the position of the rail car along the length of the track. With Carbis' standard gangways, the rail car is generally spotted with the access area centered on the gangway. With Carbis' pivoting or tracking gangways, the rail car is generally spotted with the access area contained within the pivoting or tracking range of the gangway.
- iii) TRUCK POSITIONING  
See the specific customer-approved Final Drawing and/or scope data for the dimensions required to spot the truck for proper operation. Given the portable nature of the truck, the proper spotting is largely determined by the skill of the truck driver; therefore, the use of visual spotting aids such as bollards, curbs, painted guide lines, suspended markers (i.e., tennis balls), etc. can enhance the driver's skill in spotting the truck. See **FIGURE 1-1** below for the effects of variable truck spotting positions.



Vehicle is positioned correctly to the TCG-2500. This allows the proper placement and also prevents fall hazards on all sides.



Vehicle is positioned too close to the TCG-2500. This prevents the proper placement and also creates a fall hazard on the outboard side.



Vehicle is positioned too far from the TCG-2500. This creates a fall hazard on the inboard side.

**FIGURE 1-1**

---

## 2) INTRODUCTION

This product has been inspected and meets Carbis' Quality Control Standards. It is important that the information contained in this manual be reviewed before operating the unit, including the following:

- a) Inspect equipment upon delivery for shipping damage or loose bolts. All fastening hardware that has been factory installed has been done so to remain tight. If any fastening hardware, whether factory or field installed, has been loosened, it must be tightened before using the product.
  
- b) It is imperative that operating and maintenance personnel become familiar with the safety information contained in section **3) IMPORTANT SAFETY INFORMATION**.
  
- c) Check that all safety placards, signs, and decals are clearly visible, legible, and in good repair. Operating personnel must be familiar with the contents of such placards, signs, and decals. See section **3) v) for SAFETY SIGN DESCRIPTIONS** for the description of all safety signs that appear on the equipment described in this manual.
  
- d) **NOTICE** **AVOID PROBLEMS WITH STAINLESS STEEL BOLTS.** Keep bolts and nuts free of grime and other contaminants that may get into threads. Lubricate stainless steel bolts and nuts prior to tightening. Avoid the use of impact speed wrenches. If one is used, a slower speed will allow heat to dissipate as the connection is tightened.

---

### 3) IMPORTANT SAFETY INFORMATION

#### a) GENERAL

This section is a compilation of all of the various hazards and safety messages relative to the equipment described herein and as depicted on the drawings. Some are duplicates of safety messages used in various sections throughout this manual, while others appear only the one time in this section. The hazards shown in this section are listed in order of greatest to least risk as DANGER, WARNING, CAUTION, and NOTICE, identified as follows:

- i) **DANGER:** Indicates a hazardous situation that, if not avoided, will result in death or serious injury.
- ii) **WARNING:** Indicates a hazardous situation that, if not avoided, could result in death or serious injury.
- iii) **CAUTION:** Indicates a hazardous situation that, if not avoided, could result in minor or moderate injury.
- iv) **NOTICE:** Indicates information considered important, but not hazard-related (e.g., messages relating to property damage).

#### b) HAZARDS

Following are the safety messages grouped by hazard as used throughout this manual:

i)  **DANGER**

The icon consists of a white exclamation mark inside a red triangle, which is itself inside a red rectangular box.

- (1) This equipment CAN conduct electricity.
  - (a) Any grounding that may be required is to be performed per the owner's safety code.
  - (b) Do NOT allow this unit to come in contact with live electrical wires.
  - (c) Do NOT handle live electrical wires while standing on or in contact with this unit.

**Failure to comply with these warnings WILL result in serious injury or death.**

ii)  **WARNING**

The icon consists of a white exclamation mark inside a black triangle, which is itself inside an orange rectangular box.

- (1) Correct vehicle positioning and proper deployment of Carbis equipment are imperative to its function. Incorrectly positioned vehicles, or improper use of this equipment, increase the risk of serious injury or death. Carbis equipment is designed to function only as described in the manual and depicted on the drawings. **IT IS THE SOLE RESPONSIBILITY OF THE OWNER TO ENSURE PROPER USE OF CARBIS EQUIPMENT.**
- (2) Before accessing Carbis equipment, a vehicle must be in the correctly spotted position and the Carbis equipment properly deployed, supported, and secured.
- (3) Personnel must not access Carbis equipment during any controlled operation.
- (4) Nonessential personnel must stay clear of Carbis equipment during any controlled operation.
- (5) Operator must be certain that nonessential personnel are clear of Carbis equipment during any controlled operation.
- (6) Operator must not place Carbis equipment in motion while occupying the same equipment.



- (7) Carbis equipment must never be forced, by any means, to overcome any seen or unseen obstacle or obstruction.
- (8) Keep hands clear of chains while gangway is in motion.
- (9) If the equipment will not function as intended, discontinue use and contact Maintenance immediately.
- (10) Never make repairs of damaged or missing parts. Replace missing parts only with approved equal parts.
- (11) Material being loaded onto/into vehicles or unloaded from vehicles may present a health hazard. It is the sole responsibility of the owner to ensure that operating personnel are familiar with any hazards associated with the material, and to implement the appropriate safety measures to protect personnel against such hazards.

**Failure to comply with these warnings COULD result in serious injury or death.**

iii)

A yellow rectangular sign with a black triangle containing a white exclamation mark, followed by the word 'CAUTION' in bold black capital letters.

- (1) Read this manual carefully before unpacking or installing Carbis equipment.
- (2) Only qualified personnel in good physical condition, trained in the proper operation of this equipment, should be permitted to operate it.
- (3) Appropriate Personnel Protective Equipment (PPE), such as gloves, safety glasses, safety shoes, etc., should be worn at all times during operation of this equipment.
- (4) For chain-supported Carbis gangways, both chains must be properly and equally engaged in the chain locks to support the gangway before accessing. Slack or unequal chain adjustment may result in unanticipated movement and loss of balance when standing or walking.
- (5) For operator safety, equipment should be stored and not used if wind speed exceeds Carbis' recommended safe working wind speed limit of 35 mph.

**Failure to comply with these cautions COULD result in personnel injury or damage to equipment.**

iv)

A blue rectangular sign with the word 'NOTICE' in white capital letters.

- (1) The gangway assembly ships with the chain links engaged in the slots of the chain locks to hold the gangway secure in the stored position. Do not disengage the chain links from holding the gangway secure in the stored position until **after** the gangway base tread has been securely installed.

v) SAFETY SIGN DESCRIPTIONS

Following are the descriptions of the safety signs that appear on the equipment described in this manual.

AL-157

AL-159.1

AL-156

AL-027-99

**SAFETY INSTRUCTIONS**

1. Ensure gangway is in the fully stored position and spot the vehicle in its correct position.
2. For pivot mounted gangways, pivot the gangway to the desired position.
3. With chains inserted in the next to last link, depress the foot lock pedal (located on the right side of the gangway, if applicable), place both hands on the top handrail, and push outward. Keep hands clear of chains during all times when gangway is in motion.
4. With gangway at the desired level, adjust the chains so that both chains equally support the gangway. The chain links MUST be engaged in the slots of the chain locks. Fine adjustments may be made by twisting the chain prior to engagement.
5. If gangway is equipped with a walk surface extension, lift and slide handle (located on the right side of gangway) until extension reaches the edge of the vehicle. Secure the extension handle in place in the grating.
6. If equipment does not appear to correctly fit on vehicle or to be correctly deployed, DO NOT ACCESS. Always be aware of your surroundings.
7. After performing the required work on the vehicle, retract walk surface extension (if applicable), pivot gangway to center position (if applicable), and use the pull-up rope to return the gangway to its stored position. Make sure that the foot lock has fully engaged the foot lock bolt on the side of the gangway (if applicable). Tighten a chain to additionally secure the gangway in the stored position. Gangways not equipped with a foot lock MUST use a chain to secure the gangway in the stored position.

Refer to manual at [www.CarbisSolutions.com](http://www.CarbisSolutions.com)

AL-157

**INSPECTION & MAINTENANCE PROCEDURES**

1. This gangway should be inspected on a monthly basis as a minimum. A harsh environment and/or heavy use may dictate more frequent inspections.
2. Visually inspect the gangway before each use. Do NOT use if any parts are damaged or missing. Never make repairs to damaged or missing parts. Replace missing parts with approved equal parts.
3. Inspection of springs should include a check of the number of coils wound around the spring clip on each end. A minimum of TWO full coils is required.
4. Walk surfaces should be kept clean and, so far as possible, dry.

**SPRING ADJUSTMENT**

If the gangway is either dropping or rising in the working range, then spring adjustment is needed.

1. With the gangway in the stored position, raise or lower one spring ear in 1/2" inch increments by turning the head of the bolt on the spring adjuster. Make sure the double jam nuts on the bottom of the bolt do not come loose.
2. Check the operation of the gangway.
3. If multiple adjustments are needed, alternate between the left and right side spring adjuster.

SYMPTOM: Gangway is hard to lift from the working position.  
CURE: Raise the ears.

SYMPTOM: Gangway will not stay down in the working position.  
CURE: Lower the ears.

See manual at [www.carbissolutions.com](http://www.carbissolutions.com)  
Contact Sam Carbis Solutions Group LLC for replacement parts.

AL-159.1

**WARNING**

**Chains must be supporting gangway prior to access.**

See instruction label.

**Keep hands clear while gangway is in motion.**





**Capacity 500 LBS**

AL-156

L  
O  
C  
K  
E  
X  
T  
E  
N  
S  
I  
O  
N  
A  
R  
M  
P  
I  
N  
I  
N  
F  
L  
O  
O  
R  
B  
E  
F  
O  
R  
E  
U  
S  
I  
N  
G



AL-305

 <b>DANGER</b>	<p>This unit <b>CAN</b> conduct electricity. Grounding requirements determined by company safety code.</p> <p>Do not allow this unit to contact live electrical wires.</p> <p>Do not handle live electrical wires while standing on or in contact with this unit.</p> <p>Failure to comply with these warnings <b>WILL</b> result in serious injury or death.</p>
	

AL-305

AL-160

<b>NOTICE</b>
<p>Tighten a chain to additionally secure gangway in stored position. Gangways without a foot lock <b>MUST</b> use a chain to store gangway.</p>
AL-160

AL-162

**Rope **MUST** be used to raise gangway**

AL-162

AL-163

**This LRD<sup>TM</sup> is a piece of safety equipment.  
Do **NOT** remove.**

AL-163

---

#### **4) PRODUCT DESCRIPTION:** **MANUALLY OPERATED TCG-2500 GANGWAY**

##### **SEE PROJECT-SPECIFIC DRAWINGS, FIGURES WITHIN THIS SECTION, AND SECTION 11) DRAWINGS AND SPECIFICATIONS**

#### **a) GENERAL**

The TCG-2500 Series Gangway is a manually operated, spring-assisted, articulating gangway that provides safe access to the tops of various types of truck and rail car vehicles of varying heights for operators to safely perform the work required on the vehicles within fall protection enclosures that are typically associated with the gangway.

- i) The TCG-2500 Series Gangway requires assembly before use. See section **5) ASSEMBLY** for instructions.
- ii) The load capacity for Carbis series TCG-2500 gangways is 500 lbs.

#### **b) MECHANICAL EQUIPMENT**

See **FIGURE 4-1** below.

##### **i) GANGWAY**

The TCG-2500 Series Gangway includes the following features:

- (1) A galvanized steel base tread that is either fixed mounted directly to a platform, horizontally pivot mounted, or track mounted
- (2) The gangway consists of stringers that articulate about the base tread and top handrails and midrails that pivot about the base tread uprights. The outboard uprights support the outer end of the top handrails and midrails, and serve as a support for safety cages or seatainer treads. Walk surface options are open serrated metal plank, fiberglass, or serrated bar grating, and are so noted on the Final Drawings. Gangway material options, as designated by the letter in the model number noted on the Final Drawings, are:
  - (a) A – Aluminum
  - (b) S – Mill Steel
  - (c) P – Primed Steel
  - (d) G – Galvanized Steel
- (3) A platform extension with an extension handle is mounted under the main gangway walk surface, and telescoping handrails are mounted on the top handrail.
- (4) Bumpers mounted on the bottom leading edge of the stringers give added protection against vehicle damage.
- (5) A foot lock mounted on the base tread holds the gangway in the upright stored position. For gangways without foot locks, the use of chains noted below are required to hold the gangway in the stored position.
- (6) Adjustable chains that are attached to the stringers and supported by slotted tube chain locks on the base tread uprights hold the gangway in any desired position within the normal working range of 15 degrees above to 15 degrees below horizontal. The range may be modified within the limits to accommodate options. The slotted tube design keeps the chain locked throughout the full range of

- gangway movement from the lowest working position up to the fully raised stored position. The chains add strength and stability to the equipment while allowing a variety of vehicles to be accessed. The chains should be used for overnight or long-term storage of the gangway.
- (7) Covered springs mounted between the uprights and the stringers provide tension adjustment to minimize the push/pull force required to articulate the gangway.
  - (8) A pull-up rope aids in returning the gangway to the upright stored position.
  - (9) For any gangway used in concert with elevating cages, platforms, and Modals, additional grab rails are employed perpendicular to the outboard uprights each side of the gangway to cover the gap created by the opening in the inboard handrail that accommodates the gangway.
  - (10) Each gangway includes a specific serial number located on the inside end of the right stringer toeboard and is visible when the gangway is stored.

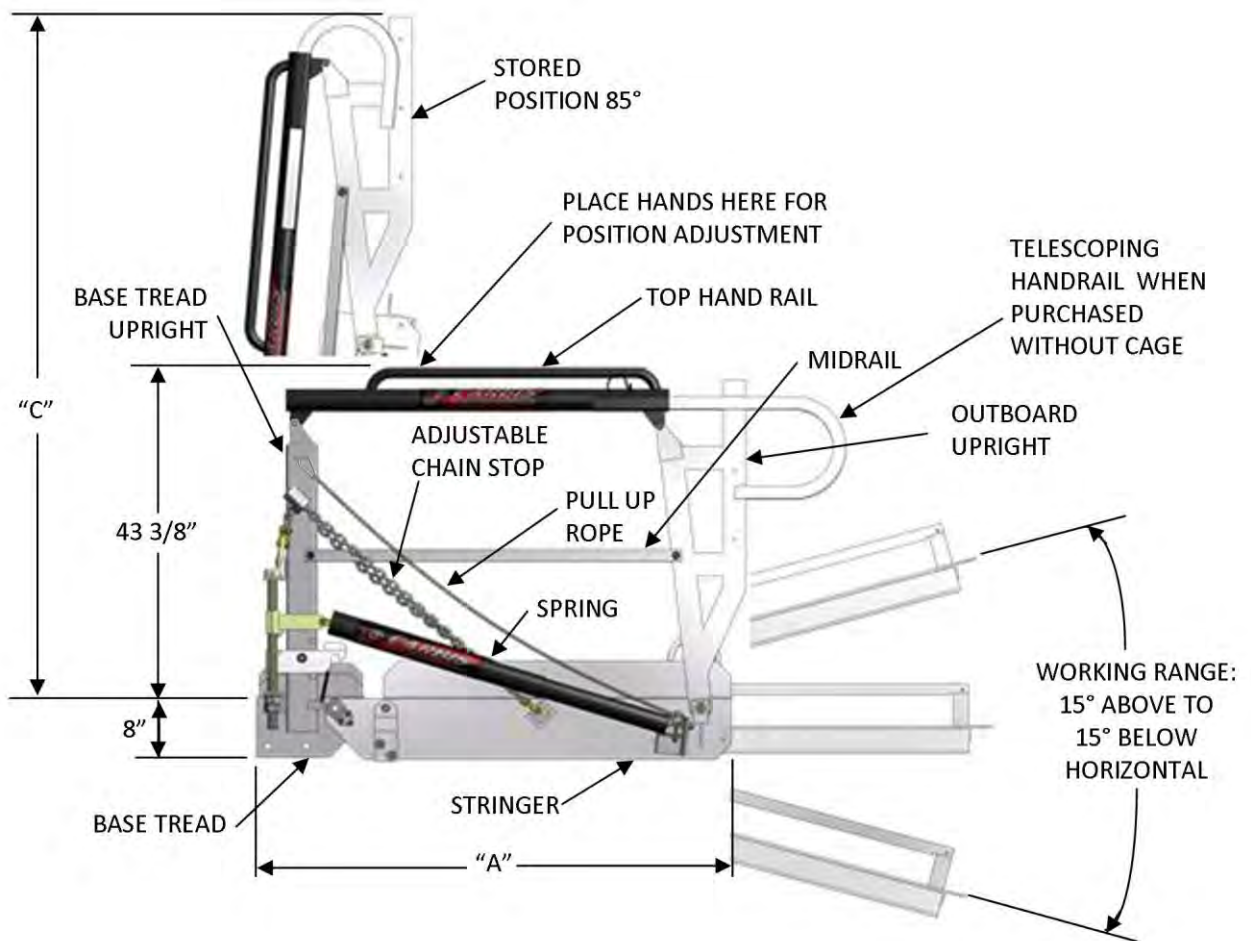

**FIGURE 4-1**

ii) MODIFIED GANGWAY

For any TCG-2500 that has been modified, or that includes the addition of ancillary components not otherwise identified above, see project-specific drawings that reflect the modification or addition.

c) OPTIONAL TCG TRACK AND CARRIAGE WITH TCG-S910.1 TRACK LOCK MECHANISM

i) TRACK AND CARRIAGE

See **FIGURE 4-2** and **FIGURE 4-3** below.

The galvanized steel track and carriage system includes the following features:

- (1) A track assembly that is either integral with a platform structure or a separate assembly that bolts to the face of a fixed platform structure
- (2) A gangway base tread mounted on a carriage that rolls on the track
- (3) The track top section captures the top rollers and the bottom section supports the carriage rollers.
- (4) A removable stop inserted through end holes in the top surface prevents the carriage from rolling past the ends of the track.
- (5) The main carriage assembly consists of a plate weldment with top and bottom rollers mounted at each end. The top rollers ride on the vertical inside leg of the track, and the bottom rollers ride on the bottom outside face of the carriage mounting plate that is bolted to the back side of the gangway.
- (6) The carriage rolling assemblies consist of rollers supported by shafts mounted on the base tread mounting plate.

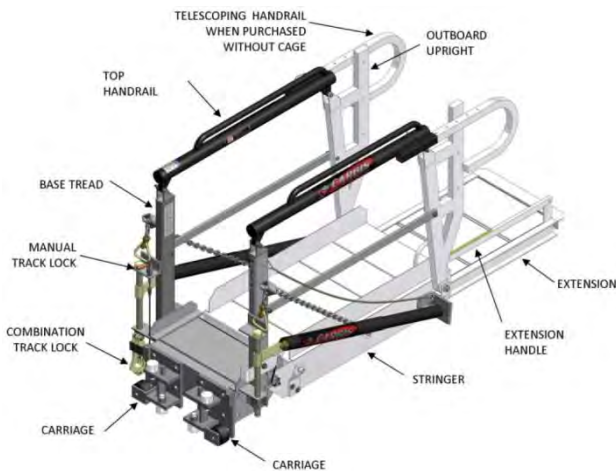

**FIGURE 4-2**

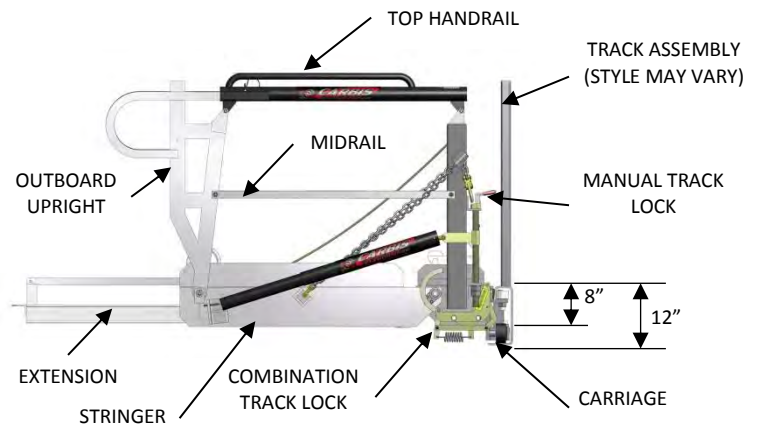

**FIGURE 4-3**



---

ii) TCG-S910.1 TRACK LOCK MECHANISM

See **FIGURE 4-4** below.

Any TCG gangway that includes the track and carriage option also includes the TCG-S910.1 Track Lock Mechanism, which is a safety device designed to prevent a manually tracked gangway from being rolled along the track when the gangway is not in the upright stored position. The mechanism consists of a combination of both automatic and manual lock functions as described below. **NOTE:** There is a patent/patent pending for the TCG-S910.1 Track Lock Mechanism.

- (1) The automatic function of the mechanism consists of the following features:
  - (a) The TCG-S910.1 Track Lock Mechanism is an assembly that contains a housing with a curved release lever arm on one end and a brake pad pivot arm on the opposite end. The two arms are sandwiched between and bolted to the side plates of the housing at the upper pivot point of each arm. Bolted between the arms below the housing is a pair of flat bar spacers that allow the arms to pivot together. Pinned between a bottom extension on each arm is an extension spring that changes the geometry of the top end of each arm as the spring is extended or released.
  - (b) The assembly bolts through holes in the side plate of the gangway base tread. The top of the curved release lever arm includes a bent leg that engages with the top edge of the gangway stringer as the gangway is raised to the stored position. The brake pad on the brake pad pivot arm engages with the outer surface of the track on which the gangway rolls.
  - (c) As the gangway body is raised to the stored position, the stringer engages the bent leg of the release lever arm which causes the spring to extend. As the spring extends, the brake pad pivot arm pivots which causes the brake pad to disengage from the track. With the gangway fully raised in the stored position, the brake pad is released from the track which allows the gangway to be manually tracked.
  - (d) Whenever the gangway is deployed in any position that is not stored, and the release lever arm is disengaged from the stringer, the spring causes the brake pad to press against the track, thereby preventing the gangway from tracking while deployed.
- (2) Whenever the gangway is stored, the automatic lock function of the track lock mechanism is inactive, which allows the gangway to freely roll along the length of the track. As an added safety feature, the track lock mechanism includes a manual track lock lever that is only deployed when the gangway is in the stored position and not being used. When engaged, the manual track lock lever causes a second brake pad to engage with the track, which prevents the gangway from being inadvertently rolled along the track by any external force such as wind.



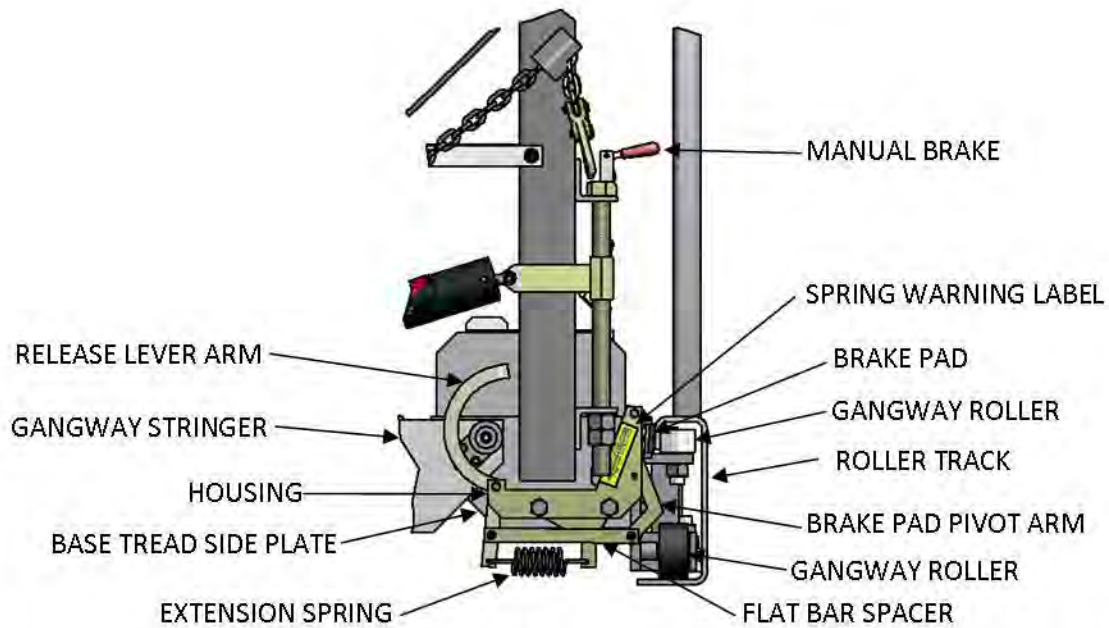

**FIGURE 4-4**

**d) OPTIONAL TCG PIVOT MOUNT**

See **FIGURE 4-5** and **FIGURE 4-6** below.

- i) The pivot mount system consists of a gangway base tread with a male pivot post mounted on the underside and a tread extension mounted on the platform side of the tread, and includes the following features:
- (1) The male pivot post engages with a female pivot-mounting sleeve and rests on a wear pad.
  - (2) The range of pivot rotation is 10 degrees each side of center.
  - (3) Brackets that are bolted or welded to a platform, either surface mounted or underslung below the platform structure, support the female pivot-mounting sleeve.
  - (4) The pivot-mounting system can also be modified to retrofit an existing pivot support bracket.



**FIGURE 4-5**

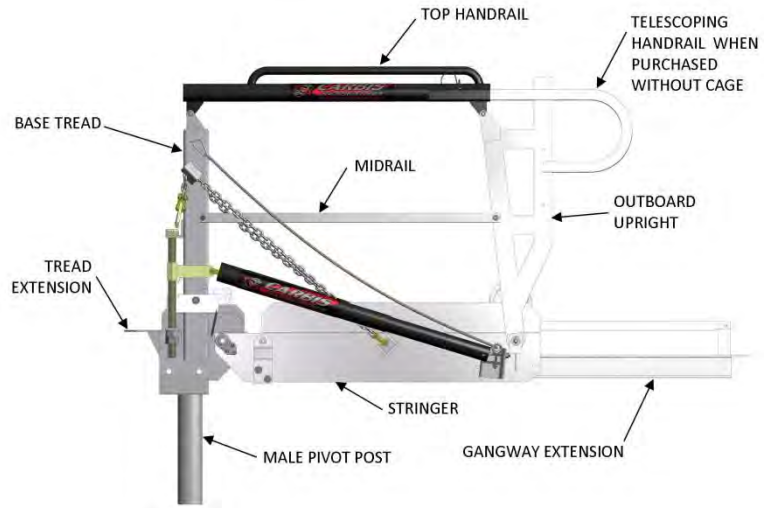

**FIGURE 4-6**

---

## 5) ASSEMBLY

### SEE PROJECT-SPECIFIC DRAWINGS, FIGURES WITHIN THIS SECTION, AND SECTION 11) DRAWINGS AND SPECIFICATIONS

#### a) GENERAL

- i) Carbis must approve any alterations required to this system.
- ii) It is the Owner's responsibility to:
  - (1) Ensure that their existing structure supports new Carbis equipment
  - (2) Identify to Carbis any conditions or obstructions that may interfere with the location or proper operation of Carbis equipment
  - (3) Remove or relocate any obstructions in preparation for installation of the new Carbis equipment

#### b) INSPECTION AND OFF-LOADING

- i) Care has been taken to package Carbis equipment and components in the best manner possible for safe shipping and practical off-loading purposes.
- ii) The gangway assembly will ship with the gangway locked in the stored position and the chain links so engaged as to hold the gangway locked in the stored position.

**NOTICE**

Do not disengage the chain links from holding the gangway in the stored position until after the gangway base tread has been securely installed.

- iii) It is the owner's responsibility to inspect the shipment for completeness by comparing the shipment with the parts identified in the Parts Lists, including the items identified in the Hardware and Pneumatic Component Lists. Check for any shipping damages or missing components, and report the same to Carbis.
- iv) It is also the owner's responsibility to provide the appropriate off-loading devices to safely and effectively rig and handle the Carbis equipment and components during the off-loading process, paying particular attention to eccentric loading conditions such as counterweighted components, including those whose eccentric loads are visually apparent.
- v) Some components may ship pre-assembled.
- vi) GANGWAY LIFT POINTS  
See **FIGURE 5-0** below.  
Make certain when lifting the gangway to secure any external lifting device only at the lift points identified by the yellow "LIFT HERE" labels posted on the outside faces of the top horizontal cross members of the outboard uprights as identified in **FIGURE 5-0** below.



FIGURE 5-0

**c) SITE PREPARATION**

- i) It is the owner's responsibility to prepare the site for new Carbis equipment. Site preparation includes, but is not limited to, the following:
  - (1) Removal and/or relocation of existing obstructions
  - (2) Field drilling mounting holes, where required, per mounting hole patterns as shown on the Final Drawings
  - (3) Adding any new customer-supplied members to existing structures as required by the new Carbis equipment
  - (4) Any foundation work required by new Carbis equipment should be constructed using only the information on the Final Drawings.

**d) ASSEMBLY**

i) REQUIRED BOLT TENSIONING FOR STRUCTURAL CONNECTIONS

(1) A325 Bolts - Snug Tight Condition

- (a) The snug tight condition is defined as the tightness that exists when all plies in a joint are in firm contact. This may be attained by a few impacts of an impact wrench or the full effort of a man using an ordinary spud wrench. Carbis' standard bolt installation is snug tight in a bearing type connection. Different requirements will be specifically detailed on the drawings.
- (b) Any bolts less than 1/2" diameter, torque to 60 in.-lbs.

(2) Stainless Hardware - Snug Tight Condition

- (a) The snug tight condition is defined as the tightness that exists when all plies in a joint are in firm contact. This may be attained by the full effort of a man using an ordinary spud wrench. Carbis' standard bolt installation is snug tight in a bearing type connection. Different requirements will be specifically detailed on the drawings.
- (b) Keep bolts and nuts free of grime and other contaminants that may get into threads. Lubricate stainless steel bolts and nuts prior to tightening.
- (c) Any bolts less than 1/2" diameter, torque to 60 in.-lbs.

- ii) A qualified erector should perform the assembly and installation of the Carbis equipment in conformity with industry standards and local building code requirements, and in accordance with the most recent industry practices for safe rigging. The procedures outlined in this section describe safe and practical sequences. Any deviation preferred by the erector/rigger must be in conformance with the above-referenced standards, codes, and practices. See Final/Assembly Drawing for Carbis-supplied components and hardware lists. Foundation anchor bolts to be supplied by customer.

iii) TRACK AND CARRIAGE OPTION WITH TCG-S910.1 TRACK LOCK MECHANISM

For existing platforms, use customer-supplied hardware to mount the tracks to the platform. For Carbis-supplied platforms, Carbis will drill the bolt holes and supply the hardware for mounting the tracks.

Install the track and carriage per the following sequence; for Carbis-supplied platforms with built-in tracks, skip steps (1) and (2):

- (1) Bolt track section(s) to platform.
- (2) Tighten track mounting bolts only after all track sections have been installed.
- (3) Insert track stop components at one end of the track run.
- (4) Slide gangway into the track section.
- (5) Insert track stop components at opposite end of the track run.
- (6) With the gangway locked in the upright stored position, push the manual track lock lever down to engage the brake to prevent the gangway from free-rolling along the track.
- (7) Disengage the chains from holding the gangway in the stored position, and reposition the chains with the next to the last link engaged in the slot of the chain lock to begin operation.
- (8) For retrofit of the TCG-S910.1 Track Lock Mechanism on an existing gangway, see section **7) MAINTENANCE** for the installation procedure.

iv) PIVOT MOUNT OPTION

See **FIGURE 5-1** below.

If Carbis supplies the platform for pivot-mounted gangways, then Carbis will supply the mounting hardware; otherwise, use customer-supplied hardware to install the pivot mount per the following sequence:

- (1) Attach the pivot mount receiver sleeve support component (face mounted or underslung mounted) to the platform structure.
- (2) Install the wear pad on the top of the sleeve opening.
- (3) Insert the base tread pivot post into the sleeve.
- (4) Disengage the chains from holding the gangway in the stored position, and reposition the chains with the next to the last link engaged in the slot of the chain lock to begin operation.

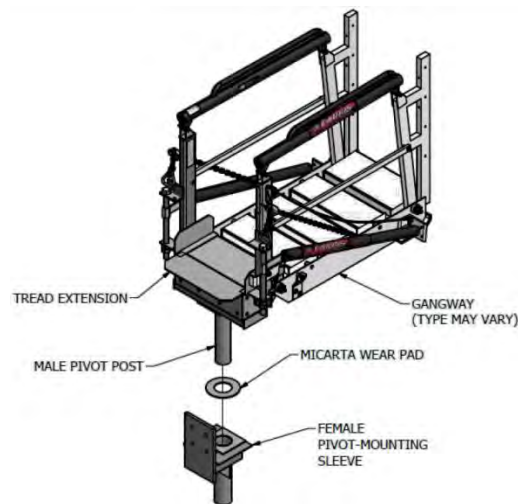

**FIGURE 5-1**

v) GANGWAY MOUNT

If Carbis supplies the platform for the gangway, then Carbis will supply the mounting hardware; otherwise, use customer-supplied hardware to install the gangway per the following sequence:

- (1) Bolt the base tread of the gangway to the platform structure.
- (2) Disengage the chains from holding the gangway in the stored position, and reposition the chains with the next to the last link engaged in the slot of the chain lock to begin operation. (**NOTE:** If cage option is included, do not try to lower gangway until cage is installed.)



vi) CAGE ASSEMBLY OPTION

For gangways that include safety cage options, use Carbis-supplied hardware to install the cage per **FIGURE 5-2** below. Gangway and cage type may vary from that shown; however, the bolting arrangement and configuration are the same. Refer to the Final Drawings and/or Assembly Drawings to determine the site-specific cage position requirement.

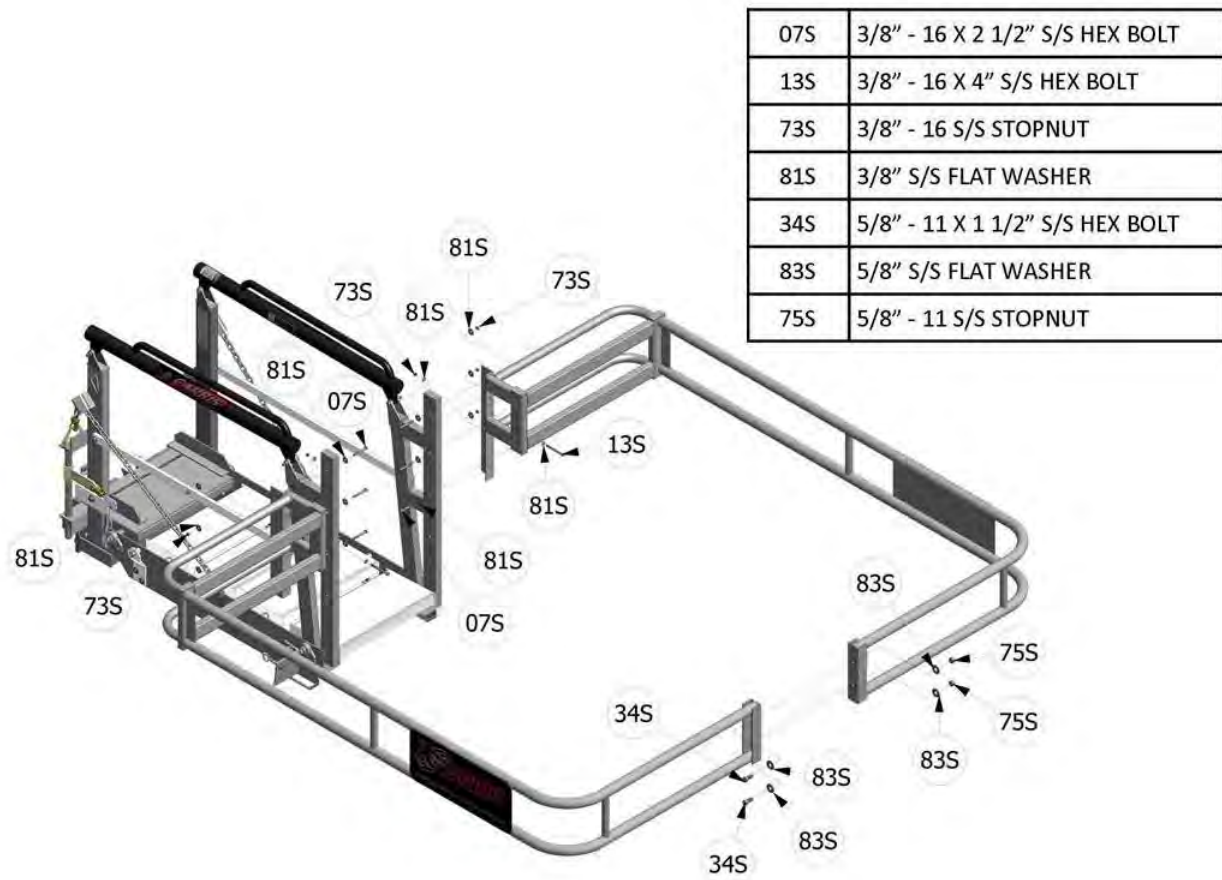

**FIGURE 5-2**

---

## 6) OPERATION

### a) GENERAL

- i) For systems that include loading arms, see separate instruction manual for operation of the loading arms.
- ii) The gangway design load limit is 500 lbs., single person occupancy.
- iii) Verify that all safety placards, signs, and decals are clearly visible, legible, and in good repair. Operating personnel must be familiar with the contents of such placards, signs, and decals. See section **3) IMPORTANT SAFETY INFORMATION** v) SAFETY SIGN DESCRIPTIONS for the description of all safety signs that appear on the equipment described in this manual.

### b) PRE-OPERATIONAL SAFETY INFORMATION

Following are the pre-operational safety messages grouped by hazard:

#### i) **DANGER**

- (1) This equipment CAN conduct electricity.
  - (a) Any grounding that may be required is to be performed per the owner's safety code.
  - (b) Do NOT allow this unit to come in contact with live electrical wires.
  - (c) Do NOT handle live electrical wires while standing on or in contact with this unit.

**Failure to comply with these warnings WILL result in serious injury or death.**

#### ii) **WARNING**

- (1) Correct vehicle positioning and proper deployment of Carbis equipment are imperative to its function. Incorrectly positioned vehicles, or improper use of this equipment, increase the risk of serious injury or death. Carbis equipment is designed to function only as described in the manual and depicted on the drawings. **IT IS THE SOLE RESPONSIBILITY OF THE OWNER TO ENSURE PROPER USE OF CARBIS EQUIPMENT.**
- (2) Before accessing Carbis equipment, a vehicle must be in the correctly spotted position and the Carbis equipment properly deployed, supported, and secured.
- (3) Personnel must not access Carbis equipment during any controlled operation.
- (4) Nonessential personnel must stay clear of Carbis equipment during any controlled operation.
- (5) Operator must be certain that nonessential personnel are clear of Carbis equipment during any controlled operation.
- (6) Operator must not place Carbis equipment in motion while occupying the same equipment.

- (7) Before operation, visually inspect the area between the equipment and the vehicle for any obstruction that would impede movement or create a tripping hazard. Remove any obstruction before operating the equipment.
- (8) Carbis equipment must never be forced, by any means, to overcome any seen or unseen obstacle or obstruction.
- (9) Visually inspect the equipment before each use. Never access damaged or broken components.
- (10) Keep hands clear of chains while gangway is in motion.
- (11) Material being loaded onto/into vehicles or unloaded from vehicles may present a health hazard. It is the sole responsibility of the owner to ensure that operating personnel are familiar with any hazards associated with the material, and to implement the appropriate safety measures to protect personnel against such hazards.

**Failure to comply with these warnings COULD result in serious injury or death.**

iii)  **CAUTION**

- (1) Only qualified personnel in good physical condition, trained in the proper operation of this equipment, should be permitted to operate it.
- (2) Appropriate Personnel Protective Equipment (PPE), such as gloves, safety glasses, safety shoes, etc., should be worn at all times during operation of this equipment.
- (3) Make certain that walk surfaces are free of product that would otherwise interfere with the safe, slip-resistant feature of the walk surface. The walking-working surfaces of every work area are to be kept in a clean and, so far as possible, dry condition.

**Failure to comply with these cautions COULD result in personnel injury or damage to equipment.**

iv)  **NOTICE**

- (1) The gangway should be in the stored position, with the gangway locked, before spotting any vehicle.

**c) OPERATING SEQUENCE**

- (1) Spot the vehicle to be accessed with the work area in front of the gangway. Use whatever visual aids are provided, if any, to assist in spotting the vehicle.
- (2) For pivot-mounted gangways, pivot the gangway to the desired position.
- (3) For track-mounted gangways, perform the following sub-steps:
  - (a) With the gangway body locked in the upright stored position, release the manual track lock lever and manually roll the gangway to the desired working position.
  - (b) With the gangway in the desired working position along the track, open the swing gate, and deploy the gangway for operation. Once the gangway is released from the stored position, the brake lock pad will automatically engage the roller track, which will prevent the gangway from tracking.

 **Do not attempt to roll the gangway along the track while it is deployed; doing so can cause damage to the equipment.**

- (c)  **If the spring is broken or missing from the TCG-S910.1 Track Lock Mechanism, do not operate the gangway. If the TCG-S910.1 Track Lock Mechanism is not**

---

**working, do not attempt to repair. Contact Maintenance immediately, or contact Carbis for assistance or replacement parts.**

- (4) With the next to the last link engaged in the slot of the chain lock, depress the foot lock to release the gangway from the stored position.
- (5) Place both hands on the top handrail and push outward while the foot lock is depressed.
- (6) After the gangway is in the working position, adjust the chains so that both chains equally support the gangway with the chain links engaged in the slots of the chain locks.
- (7) When extending the gangway is necessary, lift the extension handle on the right side of the gangway to extend the main walk surface extension to the edge of the vehicle being accessed. Secure the extension handle in place in the grating.
- (8) After the extension has been set and locked in place, extend the telescoping handrails by removing the pins on top of the handrails, and extend them to the proper length. After the telescoping handrails are set to the proper length, secure them in place with the pins.
- (9) After performing the required work, and before leaving the vehicle, make sure the area is clear of all loose equipment and tools.
- (10) If the extension and telescoping handrails have been deployed, unpin, retract, and pin the telescoping handrails, and then lift the extension handle to return the extension to the fully retracted stored position. Secure the extension handle in place in the grating.
- (11) Make certain that no one has inadvertently raised the gangway. Exit the gangway.
- (12) Use the pull-up rope as an assist to help return the gangway to its stored position. It is not necessary to depress the foot lock pedal when raising the gangway; however, make certain that the foot lock has engaged the bolt of the foot lock mechanism.
- (13) Tighten a chain to additionally secure the gangway in the stored position. Gangways not equipped with a foot lock must use a chain to secure the gangway in the stored position.
- (14) For track-mounted TCG's, when finished with the operation, perform the following:

**NOTICE**

With the gangway locked in the upright stored position, push the manual track lock lever down to engage the brake to prevent the gangway from free-rolling along the track.

- (15) **WARNING** If the gangway will not raise or lower when pushed or pulled to the desired position, or if the foot lock will not engage, discontinue use and contact Maintenance immediately. Failure to follow instructions, or any attempt to dislodge obstructions, may result in severe injury or death.

---

## **7) MAINTENANCE**

### **a) GENERAL**

- (1) Before servicing the gangway, ensure that the equipment is properly “locked and tagged” per safety regulations. As an added safety precaution, for as long as the gangway remains in the fully raised stored position, make certain the chains are pulled taut and the links properly engaged in the slots of the chain locks.
- (2) Visually inspect the assemblies before each use. Replace any damaged parts. If component replacement requires any disassembly, refer to section **5) ASSEMBLY** to restore the system to its operational status.
- (3) Monthly inspection of the assemblies is recommended as a minimum. Harsh atmosphere and/or heavy use may dictate more frequent inspection and maintenance.
- (4) Make certain that walk surfaces are free of product that would otherwise interfere with the safe, slip-resistant feature of the walk surface. The walking-working surfaces of every work area are to be kept in a clean and, so far as possible, dry condition. Frequency of cleaning is dictated by the frequency of product build-up on the walk surfaces.
- (5) All fastening hardware that has been factory installed has been done so to remain tight. If any fastening hardware, whether factory or field installed, has been loosened, it is imperative that it be tightened before using the equipment.
- (6) Check that all moving parts are properly functioning.
- (7) Lubricate the pivot points on the handrails and main body with lightweight aerosol oil.
- (8) These units have flanged bearings with a grease fitting; the bearings should be lubricated with lithium-based grease.
- (9) See section **b)** below for **SPRING MAINTENANCE** and for procedures to unlock a spring adjustment nut that may have locked up due to a long period of inactivity.
- (10) See section **c)** below for **FOOT LOCK ADJUSTMENT PROCEDURE**.
- (11) Keep assemblies clean and free from grease, oil, mud, snow, wet paint, and any other slippery material.
- (12) Never make repairs of damaged or missing parts. Replace missing parts only with approved equal parts.
- (13) For gangways that include the track-mounted option, see section **d)** below for **TCG-S910.1 TRACK LOCK MECHANISM** for retrofit installation and maintenance requirements.
- (14) For any assistance, replacement parts, comments, or questions, please call Carbis’ Customer Service Department at 1-800-845-2387. Please have your model number, serial number, or drawing number available to expedite your request.

### **b) SPRING MAINTENANCE**

#### **i) SPRING INSPECTION**

- (1) Inspection of springs should include a check of the number of coils wound around the spring clip on each end; a minimum wind of two full coils is required.



ii) SPRING ADJUSTMENT AND REPLACEMENT

(1) To adjust spring tension or replace a spring, follow the instructions noted below:

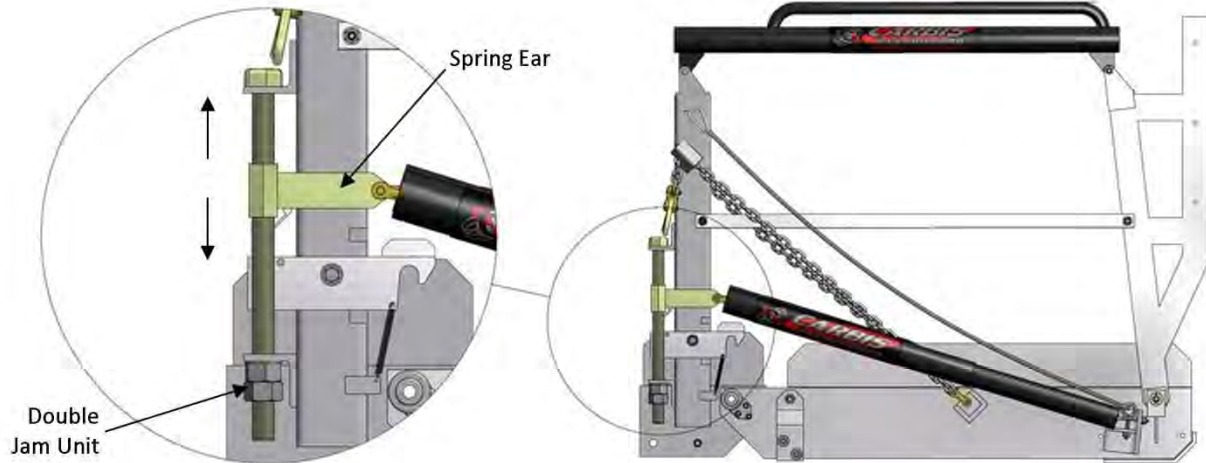

Adjustment to the spring counterbalance system may be required to change the amount of force necessary for the return of the gangway to the stored position. The springs are set at the factory for the gangway weight and any options that might have been purchased. These could include a seatainer end tread and/or a cage. It is necessary for all purchased options to be installed prior to use for the springs to properly function.

**Spring Adjustment**

Large movement of the spring is seldom the solution for spring adjustment. Adjustments in 1/2" increments and checking the balance by operating the gangway are normally enough to bring the unit into the specified pull on the rope of 50 pounds or less. Marking and/or measuring the starting location is important in saving time and not repeating a prior location.

**Symptom and Cure**

The following adjustments should only be made with the gangway in the stored position and the foot lock engaged. The bolt should be turned with the proper size wrench. The head of the bolt should be turned; do not attempt to loosen the double jam unit. If the gangway is hard to lift from the working position, raise the ear. If the gangway will not stay down in the working position, lower the ear. Again, it should only take a few 1/2" incremental changes to fine-tune your unit.

**Spring Replacement**

If the gangway requires any component of the spring counterbalance system replaced, you must follow the procedures below. If, at any time, you do not fully understand the procedures, call Carbis and ask for technical assistance.

1. With the gangway in the stored position, tie the unit off.
2. Mark the current ear location on the threaded rod.
3. Relieve all tension on the spring by raising the spring ear.
4. At this point, follow replacement instructions supplied with the spring counterbalance system.
5. Reconnect hardware as instructed.
6. Relocate the ear in the original position.
7. Untie the gangway and test the unit.
8. If adjustments are required, see Symptom and Cure.

---

iii) UNLOCKING SPRING ADJUSTMENT NUT

If a gangway operates for long periods where no spring adjustment is necessary, it is possible that, under certain environmental conditions, the spring adjustment nuts may lock onto the threads. If that happens, perform the following steps to unlock the nuts:

- (1) Make certain the gangway is locked in the stored position with the foot lock engaged and the chain taut with a link engaged in the slot of the chain lock.
- (2) Mark the location of the nut on the long threaded adjustment bolt.
- (3) Spray a penetrating lubricant catalyst (B'LASTER Penetrating Lubricant Catalyst is one brand name) onto the threads of the bolt each side of the nut and let it set up for approximately 20 minutes.
- (4) Using a 2"/50mm wrench, turn the nut ear into the gangway base tread upright which will hold the nut fixed while turning the wrench. Apply additional sufficient torque to turn the bolt while the nut remains fixed. **NOTE:** If pneumatic power is available, the use of an impact wrench will ease and speed up the process.
- (5) Once the nut freely turns on the bolt threads, adjust the position of the nut on the threads to the original mark.



c) FOOT LOCK ADJUSTMENT PROCEDURE

- i) For those installations where the Carbis TCG gangway foot lock has become misaligned to the point where the locking pin does not properly engage with the foot lock mechanism, the procedure noted below can be used to realign the locking pin with the foot lock mechanism.
- ii) The following procedure applies to all Carbis pneumatically operated and manually operated TCG-1000, TCG-2000, and TCG-2500 Series gangways with single or double foot locks:
  - (1) For safety reasons, make sure the system is properly locked and tagged to prevent inadvertent gangway operation during the foot lock adjustment procedure.
  - (2) Make certain that the gangway is fully raised and locked in the stored position.
  - (3) Pull a chain on one side of the gangway sufficiently taut with the appropriate chain link engaged in the slot of the chain lock to hold the gangway in the stored position.
  - (4) Loosen the two bolts of the locking pin assembly.
  - (5) Reposition the locking pin in the foot lock mechanism so that the pin is centered in the foot lock with a uniform clearance between the pin and the foot lock, and without the foot lock contacting the pin.
  - (6) With the locking pin centered on the foot lock, tighten the locking pin bolts.
  - (7) For gangways with double foot locks, repeat steps (3), (4), and (5) above for the second foot lock.
  - (8) Reposition the chains each side of the gangway so that the next to the last link is engaged in the slot of the chain lock for an operator to begin the operation.
  - (9) Operate the gangway through a few cycles to verify that the foot lock is properly functioning in both the lock and unlock conditions.
  - (10) If, for any reason, the above-noted procedure does not properly realign the locking pin with the foot lock mechanism, call Carbis' Customer Service Department at 1-800-845-2387.

---

**d) TCG-S910.1 TRACK LOCK MECHANISM**

See **FIGURE 7-1** below.

- i) The following maintenance procedure applies to both the replacement of an existing TCG-S910.1 Track Lock Mechanism or the new installation of the TCG-S910.1 Track Lock Mechanism as a retrofit on an existing tracking gangway system.
- ii) Using **FIGURE 7-1** below as a guide, install the replacement/new TCG-S910.1 Track Lock Mechanism per the following steps:
  - (1) Make certain the gangway body is locked in the upright stored position.
  - (2) Manually pivot the curved release lever arm sufficient so that it will engage the top edge of the stringer on the stored gangway. If the lever arm is too tight to manually hold, temporarily tie the top bend of the arm to the pivot bolt of the brake pad using string or tape that is sufficiently strong to hold the arm in place.
  - (3) Position the Track Lock Assembly so that the lever arm bent leg passes over the top edge of the stored gangway stringer as the bolt sleeves are aligned with the bolt holes on the base tread side plate.
  - (4) Using the Carbis-supplied hardware, bolt the assembly to the base tread side plate.
  - (5) If the release lever arm was tied back, release the tie so that the bent leg of the release lever arm engages the top edge of the stringer.
  - (6) With the gangway body in the raised stored position, check that the brake pad is free of the roller track and that the gangway will freely roll when manually pushed in either direction.
  - (7) Check the brake pad function by lowering the gangway body from the stored position sufficient to completely disengage the release lever arm from the gangway stringer. At that point, the brake pad should be maximally engaged with the roller track to prevent the gangway from tracking. Apply sufficient push/pull pressure on the gangway to verify that the gangway remains in position without rolling in either direction.
  - (8) Raise and lower the gangway to and from the stored position several times to confirm the consistency of the TCG-S910.1 Track Lock Mechanism function.
  - (9) Install the manual track lock lever and Carbis-supplied mounting hardware as shown in **FIGURE 7-1** below.
  - (10) Verify that the manual track lock brake engages with the track sufficient to firmly hold the gangway in place.
- iii) If the safety labels are missing or illegible, apply the Carbis-supplied labels as described below in the positions noted:
  - (1)  **DO NOT OPERATE GANGWAY IF SPRING IS BROKEN OR MISSING.** Apply this label (with the black arrow) on the mechanism as shown in **FIGURE 7-1** below.
  - (2)  **THIS UNIT IS EQUIPPED WITH AN AUTOMATIC BRAKE TO PREVENT THE GANGWAY FROM TRACKING WHILE DEPLOYED.** Apply this label to the lower portion of the left-hand upright of the gangway base tread.

- (3) **NOTICE** WITH THE GANGWAY LOCKED IN THE UPRIGHT STORED POSITION, PUSH THE MANUAL TRACK LOCK LEVER DOWN TO ENGAGE THE BRAKE TO PREVENT THE GANGWAY FROM FREE-ROLLING ALONG THE TRACK. Apply this label to the upper portion of the left-hand upright of the gangway base tread near the manual track lock lever.

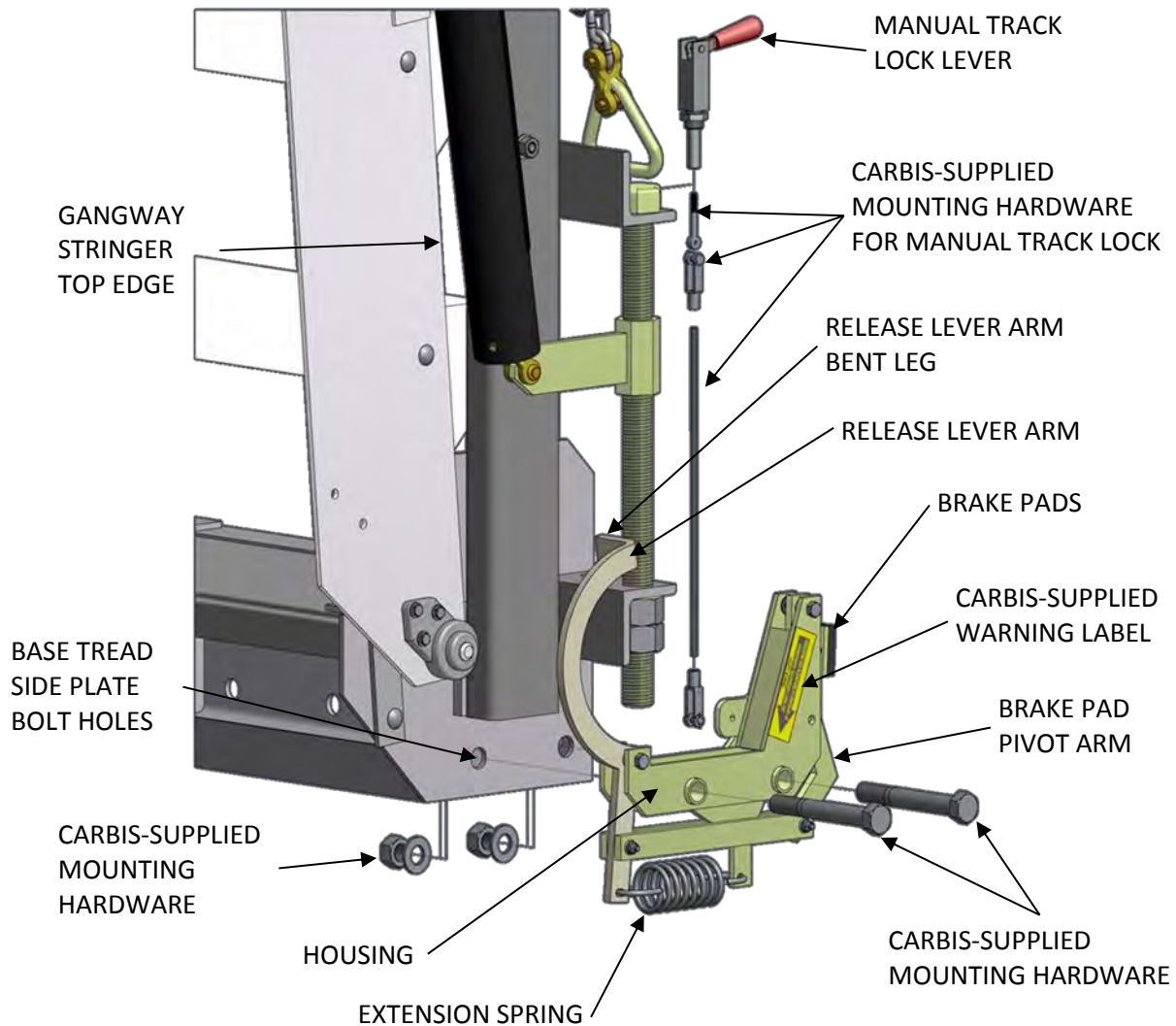

**FIGURE 7-1**



---

## **8) EXTENDED INSPECTION ADDENDUM**

The low maintenance nature of Carbis equipment means that it does not require any more stringent inspection than that noted in section **7) MAINTENANCE**. However, at the request of some customers whose internal programs require annual inspections, the following extended inspection procedure can be performed during an annual inspection:

- (1) In general, thoroughly clean the equipment to maximize visual inspection procedures.
- (2) Check all welds on all surfaces of all components, including those ordinarily hidden from view, to be certain there are no weld cracks.
- (3) Thoroughly check all surfaces of all components, including those ordinarily hidden from view, for any signs of corrosion.
- (4) Although this note is in section **7) MAINTENANCE**, its importance bears repetition here: Make certain that walk surfaces are free of product that would otherwise interfere with the safe, slip-resistant feature of the walk surface. The walking-working surfaces of every work area are to be kept in a clean and, so far as possible, dry condition.
- (5) Check all bolted connections. First, make certain that none can be hand loosened; then check the connections again using a wrench to make certain they are securely snug.
- (6) Check all rotating/pivoting connections for fit, corrosion, excessive wear, and for lubrication where required. Replace any fitting whose condition so warrants, and lubricate components as needed.
- (7) Where rolling components are employed, check that they (and their associated tracks) are:
  - (a) Properly and securely mounted
  - (b) Free of debris that would otherwise impede their rolling function
  - (c) Free of flat spots or excessive wear; replace as needed
- (8) Spring Adjustment. As a matter of standard procedure, the gangway springs are shop adjusted and set for maximum efficiency before shipment. As a result, the springs seldom need field adjustment; however, this manual includes instructions for those occasions when field adjustment is necessary, or in the event the spring adjustment nut locks up after long periods of inactivity (see section **7) MAINTENANCE**). During this extended inspection procedure, with the gangway locked in the stored position, check that the adjustment bolts are free to turn in both directions; however, make certain to restore them to the original position by marking the location of the nut on the threads before turning the bolt.



---

## 9) MANUAL BRAKE ADJUSTMENT ADDENDUM

### a) GENERAL

- i) This addendum is considered an integral part of the instruction manual for the Carbis equipment to which the addendum applies. The manual brake is a sub-assembly of the TCG S-910.1 Track Lock Mechanism associated with manually tracking gangways.
- ii)  Only qualified maintenance personnel or skilled craftsmen, trained in safe and proper maintenance procedures, should perform the adjustment of the Carbis equipment in accordance with the most recent industry practices. Failure to do so could cause personnel injury or damage to equipment.
- iii) Prior to the adjustment of any component, it is imperative that the system Lockout/Tagout Procedure be performed per company safety regulations and requirements.

### b) MECHANICAL EQUIPMENT

#### i) MANUAL BRAKE

See **FIGURE 9-1** below.

The manual brake is a sub-assembly of the TCG-S910.1 Track Lock Mechanism associated with Carbis tracking gangways. If the engagement of the manual brake is insufficient to prevent the gangway from tracking while the gangway is in the upright stored position, or if the brake lever becomes too tight to engage the brake pad, the manual brake can be adjusted per the procedure below to lock the gangway in place with the appropriate brake engagement while the gangway is in the upright stored position. For the purpose of describing the adjustment procedure, the following components of the manual brake sub-assembly as identified in **FIGURE 9-1** below will be included in the procedure:

- (1) Lever
- (2) Lever Clamp
- (3) 3/4" Nut
- (4) 5/16" Jam Nut
- (5) Threaded Rod

### c) MANUAL BRAKE ADJUSTMENT PROCEDURES

#### i) GENERAL

Using **FIGURE 9-1** below as a guide, perform the following steps to adjust the manual brake:

- (1) With the lever in the upright unlocked position, secure the lever clamp in place and loosen the 5/16" jam nut on the threaded rod first, and then loosen the 3/4" nut on the lever clamp.
- (2) With both nuts loosened and the lever in the upright unlocked position, manually turn the lever clamp one complete turn (360 degrees).
  - (a) Turning the clamp clockwise will tighten the brake engagement, which will increase the braking strength.
  - (b) Turning the clamp counterclockwise will loosen the brake engagement, which will decrease the braking strength.
- (3) With the lever in the upright unlocked position, secure the lever clamp in place and tighten the 3/4" nut on the lever clamp first, and then tighten the 5/16" jam nut on the threaded rod.

- (4) Push the lever down to the horizontal locked position and test the brake engagement. If a push-pull test tool is available, a properly adjusted manual lock braking mechanism was shop tested to resist 300 lbs. of push-pull force.
- (5) If the brake engagement is insufficient, or if the lever is still too tight, repeat steps (1) thru (4) to achieve the desired results.

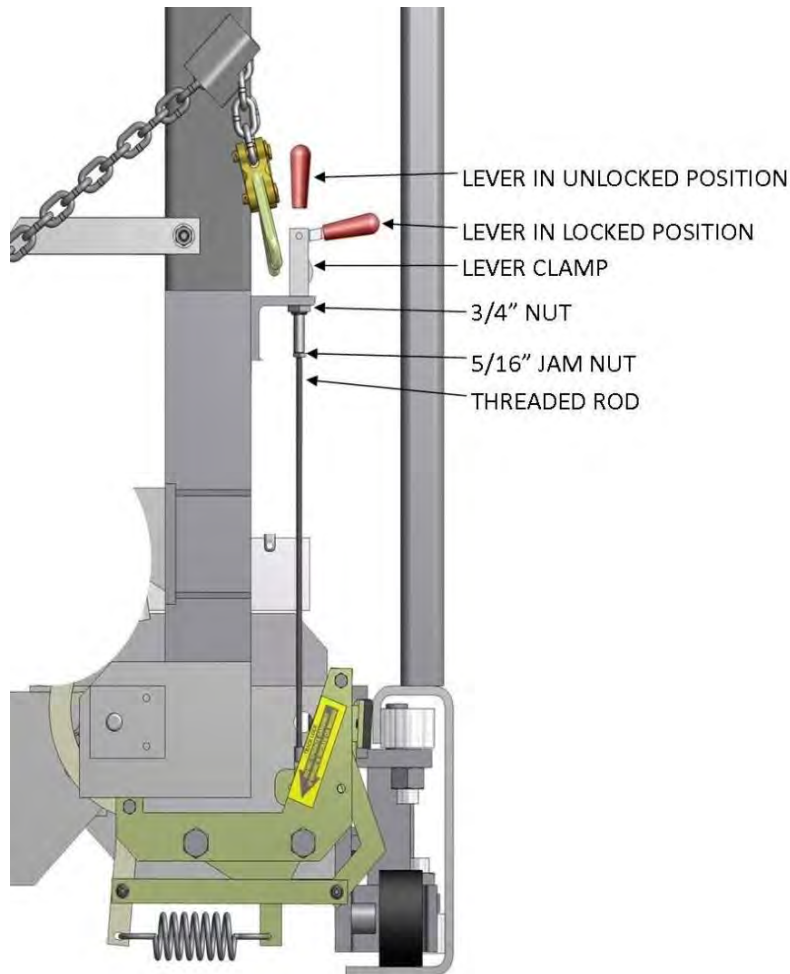

**FIGURE 9-1**  
**MANUAL BRAKE SUB-ASSEMBLY**  
**OF THE TCG-S910.1 TRACK LOCK MECHANISM**

- ii) For any assistance, replacement parts, comments, or questions, call Carbis' Customer Service Department at 1-800-845-2387. Please have your model number, serial number, or drawing number available to expedite your request.

---

## **10) LIFT RESISTING DEVICE ADDENDUM**

### **a) GENERAL**

- i) The TCG Gangway LRD (Lift Resisting Device) Lever Arm Release Handle instructions contained within this addendum apply to Carbis Manually Operated TCG Gangway Series TCG-1000, TCG-2000, and TCG-2500.
- ii) The Lift Resisting Device is designed to impede the gangway from being inadvertently or prematurely raised while the top of the vehicle is occupied by operating personnel. The Lever Arm Release Handle is designed to release the LRD while simultaneously raising the gangway to the stored position as an operator exits the gangway.
- iii) This addendum is considered an integral part of the instruction manual for the gangway to which the Lift Resisting Device and Release Handle apply.

### **b) DESCRIPTION**

- i) The Lift Resisting Device consists of the following features:
  - (1) A linear rail with ratcheting angled teeth mounted on the underside; the rail is pinned on one end to a lug that is supported on the top rail of the gangway by double U-bolts. The opposite end of the rail slides into an extension tube that is pinned to a support bolted to the outboard handrail of the gangway.
  - (2) Pinned to a lug mounted on the underside of the linear tube is a ratcheting pawl with a pivoting catch that engages a tooth of the linear rail and holds the gangway in place, which impedes the gangway lift.
  - (3) The LRD Lever Arm Release Handle is designed to actuate with a pull-up rope that is supplied with the LRD as shown in **FIGURE 10-1**. The Release Handle is mounted on the ratcheting pawl of the LRD. When the handle is pulled towards the platform with the rope, it causes the ratcheting pawl to pivot, which releases the catch from its engagement with the gear tooth of the rail and allows the gangway to be raised to the stored position with the LRD rope.

---

**c) ASSEMBLY**

- i) In most instances, the LRD assembly will be installed at the factory and will not require any additional assembly.
- ii) In the event that the LRD assembly was not initially installed by the factory, it can be installed by following these steps:
  - (1) Per **FIGURE 10-1**, perform the following steps:
    - (a) The LRDs supplied are intended to be installed such that the operating arm extends toward the outside of the gangway.
    - (b) Spot the location for two holes by measuring down a distance equal to DIM "A" from the upper end of the 3" X 1-1/2" aluminum gangway post and 1/2" and 2-1/2" from the edge as shown in **FIGURE 10-1**. Drill a 5/16" diameter hole at each location (two holes total) completely through the gangway post.
    - (c) Assemble the mounting bracket of the extension tube at the location of the drilled holes using the two 1/4" X 2-3/4" long bolts, two washers, and two lock nuts supplied. Tighten until lock nut is fully engaged and tight.
    - (d) Measure and mark a location 7" from the platform side of the handrail pivot bracket as shown in **FIGURE 10-1**. With the LRD totally assembled, center the linear rail mounting bracket at the location marked. Install the two U-bolts, spacers, and washers as supplied and tighten.
    - (e) Test the operation of the Lever Arm Release Handle by raising and lowering the gangway. Pull the LRD rope to disengage the locking mechanism in order to raise the gangway.
  - (2) When retrofitting an existing gangway installation with the LRD assembly, the existing lifting rope can be removed. Lifting can be performed using the rope attached to the LRD lever arm.

**d) OPERATION**

- i) While the deployment of the gangway does not change from the procedures noted in the standard manual, the implementation of the LRD Lever Arm Release Handle does cause the following variation in exiting and storing the gangway.
  - (1) To exit the gangway, face the platform.
  - (2) After stepping off of the gangway onto the platform, turn around facing the gangway and firmly grab the pull-up rope attached to the LRD handle. Firmly pull the rope to disengage the LRD and raise the gangway to the stored position.
  - (3) Make certain that the foot lock has engaged the bolt of the foot lock mechanism.
  - (4) From this point, follow the remaining steps in the standard manual.

SETUP DIM "A"	
1 $\frac{1}{2}$ "	LRD-3
6 $\frac{3}{16}$ "	LRD-4
10 $\frac{3}{16}$ "	LRD-5
10 $\frac{3}{16}$ "	LRD-6
10 $\frac{3}{16}$ "	LRD-7

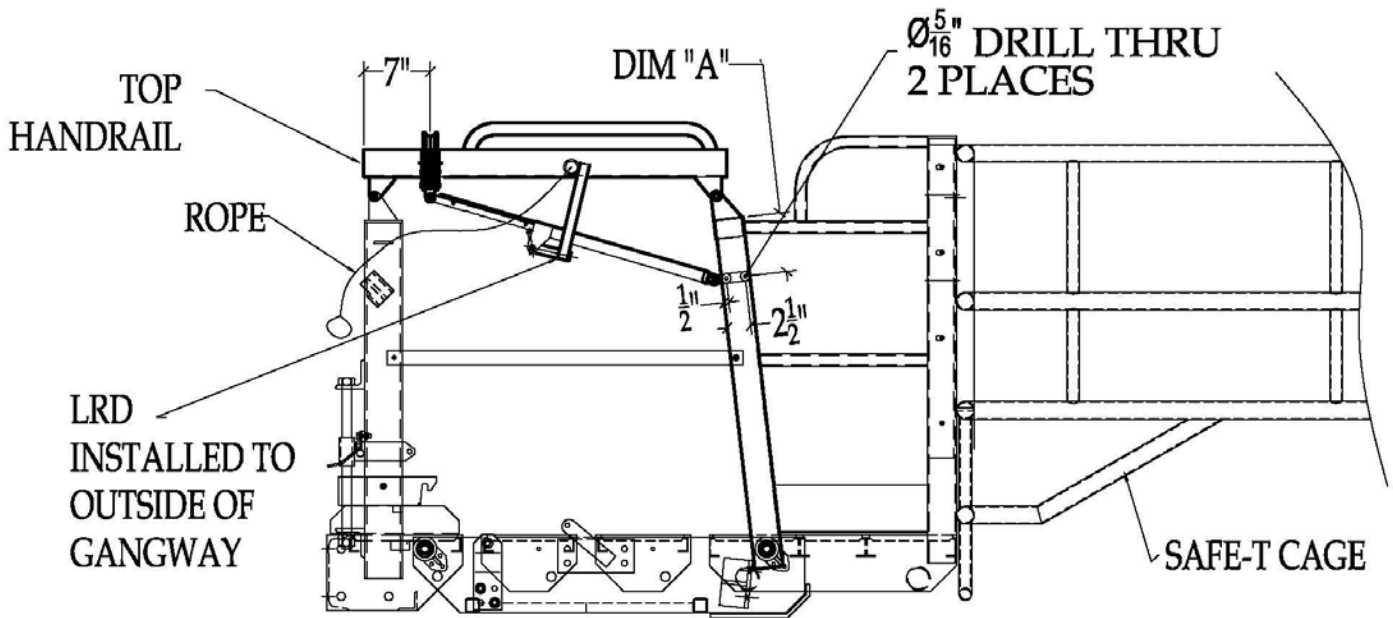

**FIGURE 10-1**



## 11) DRAWINGS AND SPECIFICATIONS

### a) GENERAL

The following pages include standard drawing dimensions and material types depicted in a combination of drawing views and charted information for various models of TCG-2500 gangways.

#### i) TCG-2500 GANGWAY MOUNTING SPECIFICATIONS

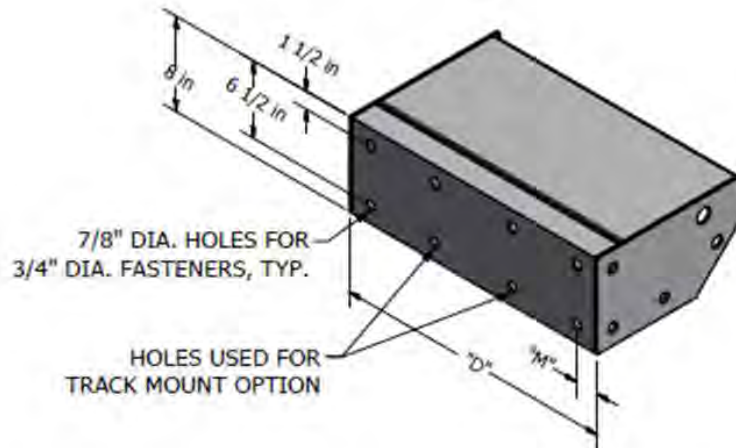

MODEL NUMBER	"D"	"M"
TCG-2500-X-A	24"	2"
TCG-2500-X-AN	18 1/4"	2"
TCG-2500-X-WA	44"	3 1/4"
TCG-2500-X-A	24"	2"
TCG-2500-X-AN	18 1/4"	2"
TCG-2500-X-WA	44"	3 1/4"
TCG-2500-X-A	24"	2"
TCG-2500-X-AN	18 1/4"	2"
TCG-2500-X-WA	44"	3 1/4"

MATERIAL CHART	
TYPE	MATERIAL
S	MILL STEEL
P	PRIMED STEEL
G	GALVANIZED STEEL
A	ALUMINUM

**NOTE:** THE "A" IN THE MODEL NUMBER DETERMINES THE MATERIAL OF THE GANGWAY. THE "A" MAY BE CHANGED TO "P", "G", OR "S" DEPENDING UPON THE MATERIAL REQUIRED. SEE MATERIAL CHART FOR SYMBOLS.

ii) TCG-2500 GANGWAY GENERAL ARRANGEMENT

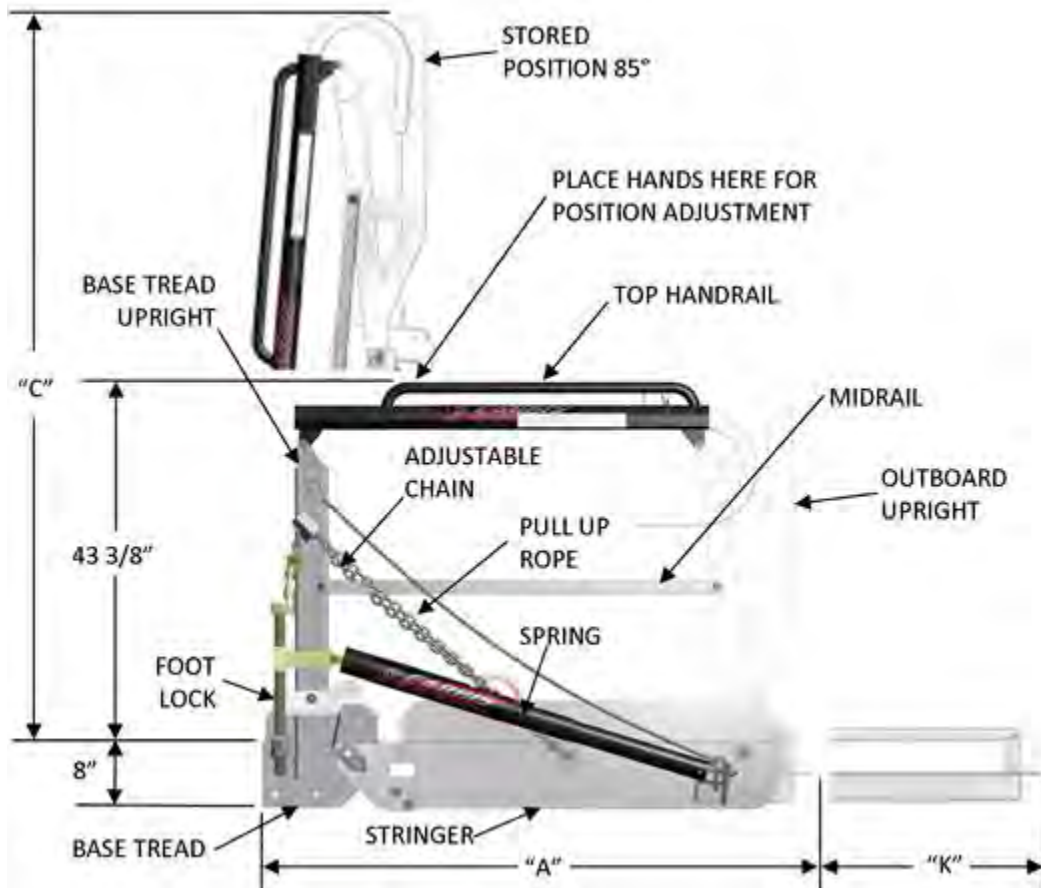
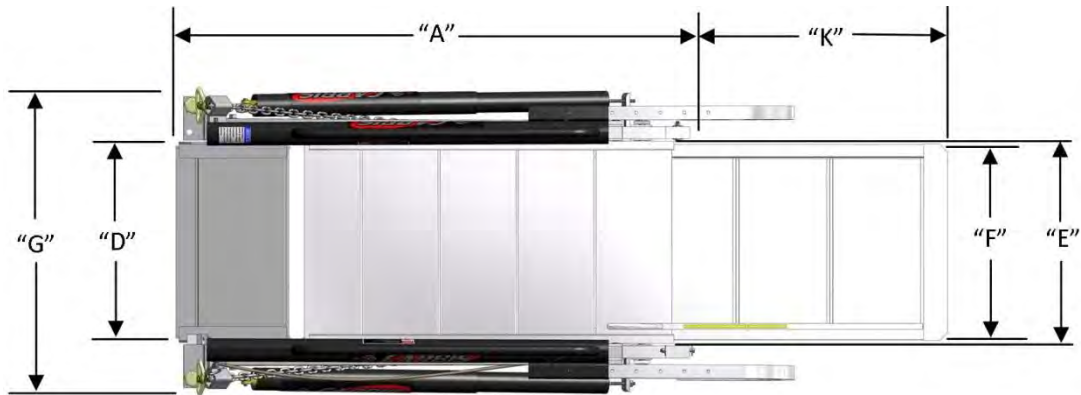

iii) TCG-2500 GANGWAY MODEL SPECIFICATIONS

MODEL NO.	"A"	"B"	"C"	"H"	"I"	"J"	"K"
TCG-2500-3	43"	19 7/8"	74"	24"	38"	32 1/4"	10"
TCG-2500-4	55"	20 7/8"	86"	36"	50"	44 1/4"	22"
TCG-2500-5	67"	22"	98"	48"	62"	56 1/4"	34"
TCG-2500-6	79"	23"	110"	60"	74"	68 1/4"	34"
TCG-2500-7	91"	24"	122"	72"	86"	80 1/4"	34"
TCG-2500-8	103"	25 1/8"	134"	84"	98"	92 1/4"	34"

WIDTH	"D"	"E"	"F"	"G"
-A	24"	28"	24 1/4"	38"
-AN	18 1/4"	20"	19"	32 1/4"
-WA	44"	48"	44 1/4"	58"

ALL OPTIONAL MOUNTING ANGLES FOR GANGWAYS ARE MADE OF STEEL.

**SPECIFICATIONS**

- ALL ALUMINUM GANGWAYS WILL HAVE GALVANIZED STEEL BASE TREADS.
- AUTOMATIC FOOT LOCK IN 85 DEG STORED POSITION
- PADDED LOWER EDGE PREVENTS VEHICLE DAMAGE
- FOR MOUNTING OPTIONS, SEE THE MOUNTING OPTION SPECIFICATION SHEET.

**OPTIONS**

- **WALKING SURFACE**  
OPEN METAL PLANK  
FIBERGLASS GRATING  
BAR GRATING
- **MATERIAL OPTIONS**  
S = MILL STEEL  
P = PRIMED STEEL  
G = GALVANIZED STEEL  
A = ALUMINUM
- **COUNTERBALANCE OPTIONS**  
SPRINGS (STANDARD)  
HYDRAULIC (OPTIONAL)  
PNEUMATIC (OPTIONAL)

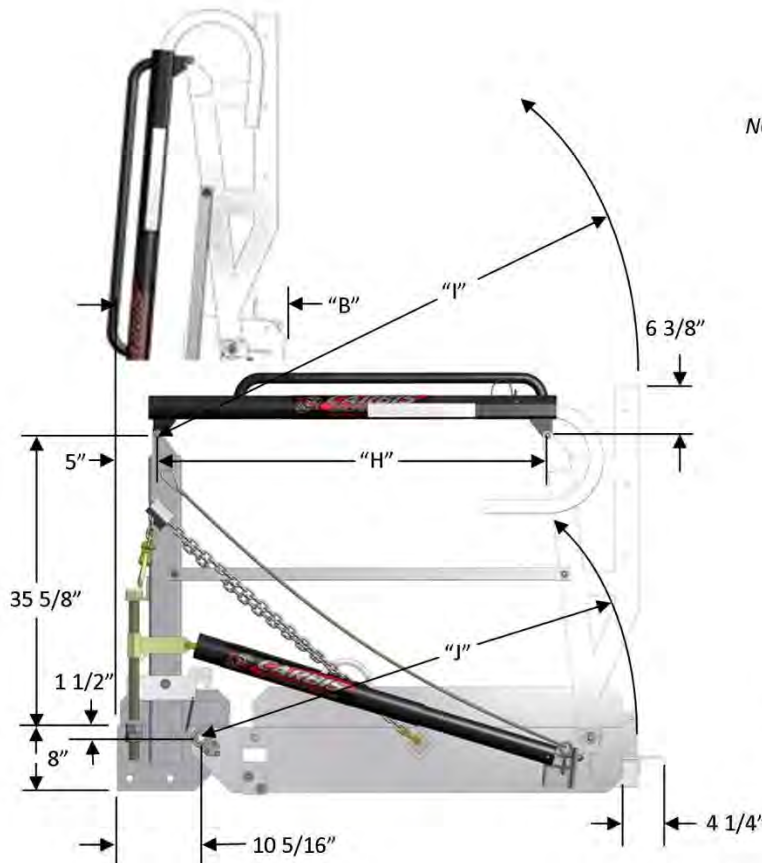

NOTE: DEPENDING UPON THE SIZE OF THE GANGWAY AND OPTIONS PURCHASED, STANDARD SPRING COUNTERBALANCE MAY NOT BE AVAILABLE FOR THAT GANGWAY

LOAD CAPACITY
FIXED MOUNT: 500 LBS
PIVOT MOUNT: 500 LBS
TRACK MOUNT: 500 LBS